

---

**FIBERLINK®**  
**XR-2500A, XR-2500A/MCR**  
**T-1 Transmission System**

# **USER'S MANUAL**



**WORLDHEADQUARTERS**  
55 Cabot Court  
Hauppauge, NY 11788 USA  
TEL: (631) 273-0404 FAX: (631) 273-1638  
WWW: <http://www.commspecial.com>  
EMAIL: [info@commspecial.com](mailto:info@commspecial.com)

**Communications Specialties Pte Ltd**  
100 Beach Road  
#22-09 Shaw Tower  
Singapore 189702  
TEL: +65 6391 8790 FAX: +65 6396 0138  
EMAIL: [csiasia@commspecial.com](mailto:csiasia@commspecial.com)

**P/N: 101973 REV. D**

---

---

---

# CONTENTS

Quick Installation Guide .....	2
General Information .....	3
Introduction	
Specifications	
Theory of Operation	
Functional Block Diagram	
Installation Instructions for XR-2500A .....	5
Installation Procedure	
Signal and Power Connections	
Operating Pointers	
Installation of XR-2500A in MCR-1000A	
Interface Troubleshooting .....	9
Operating Considerations for Fiber Optic Cable .....	10
Overall Fiber System Checkout and Troubleshooting Techniques .....	11
Maintenance .....	14
Statement of Warranty .....	15

---

## QUICK INSTALLATION GUIDE

The following is a *quick installation guide* for the FIBERLINK XR-2500A. It is intended for users familiar with the installation of fiber optic transmission systems to get “up and running” in minimal time. For additional details please consult the balance of this manual.

### Stand-Alone Version

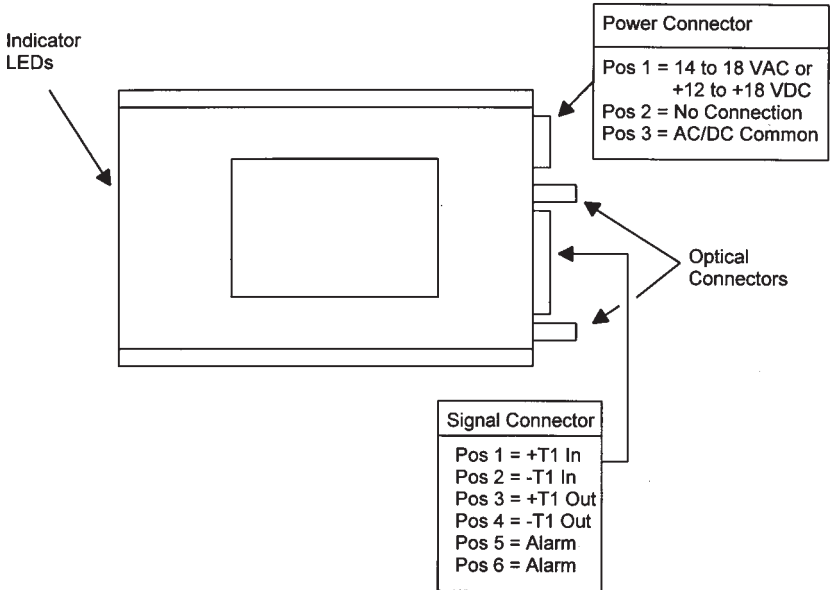

### Rack Mountable Version

The FIBERLINK XR-2500A/MCR may be plugged directly into the MCR-1000 card cage. All operating power for the XR-2500A will then be provided by the MCR-1000A card cage.

---

---

## GENERAL INFORMATION

### Introduction

The Fiberlink XR-2500A is a fiber optic transceiver utilizing circuitry that is fully compatible with EIA standard T-1 at a data rate of 1.544 Mbps. There are no operating controls on the unit. However, there are two indicator LEDs which are used to monitor operation of the unit. The XR-2500A is designed for stand-alone use. The XR-2500A/MCR is designed for use in a MCR-1000 rack mountable card cage.

### Technical Specifications

System Protocol .....	EIA T-1
System Data Rate .....	1.544 Mbps
Input/Output Impedance .....	110 ohms, balanced
Optical Loss Budget .....	50u Fiber, 0 - 8 dB 62.5u Fiber, 0 - 12 dB 8/10u SM Fiber, 0 - 8 dB
Operating Wavelength .....	850 nm or 1300 nm
Optical Connectors .....	ST, SMA or FCPC
Operating Temperature .....	-10 to +55 degrees C

---

## Theory of Operation

The transmitting section of the XR-2500A converts an incoming T-1 signal into pulses of light at the transmitting LED located in the “T” optical connector on the unit. These pulses of light equate to ON for a logic 1 (positive input) and OFF for a logic 0 (negative input).

The receiving section of the XR-2500A produces an T-1 compatible output from received light at the photodiode located in the “R” optical connector on the unit. An internal signal regenerating circuit assures that the output signal will be of the correct T-1 format, even with distorted inputs.

In addition, a carrier detector monitors the received signal pulse stream and activates a set of contacts for external alarm monitoring purposes.

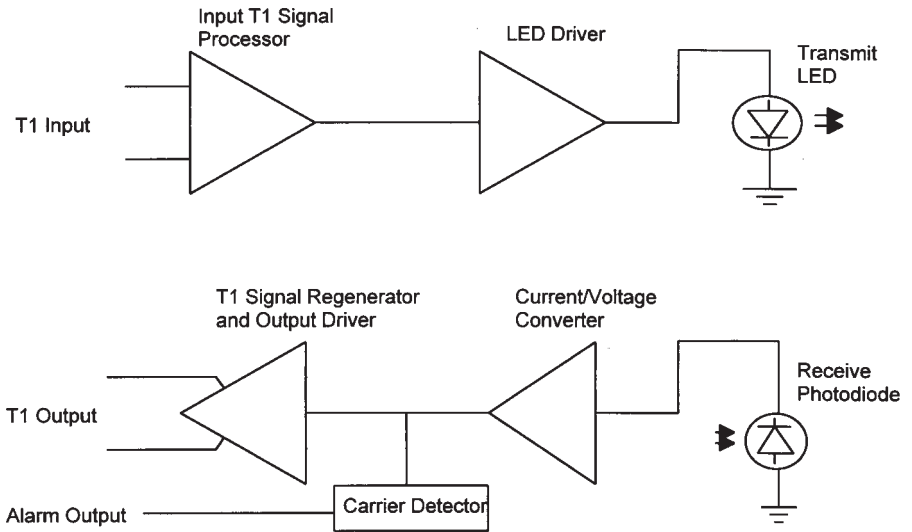

**XR-2500A T1 Transceiver Functional Block Diagram**

---

## INSTALLATION INSTRUCTIONS FOR XR-2500A

There are no operating controls on the XR-2500A. There is an internal switch however, that is set for the status of the alarm contacts. Details are as follows:

### Installation Procedure

1. Connect the T1 transmission equipment to be used to the signal positions on the terminal block of the XR-2500A. Be certain that the various connections are made properly.
2. If the external alarm contacts are to be used, set the internal DIP switch, located near the center of the printed circuit card, for the configuration desired. The NC position signifies normally closed contacts which open on loss of signal, the NO position signifies normally open contacts which close upon loss of signal.
3. Connect operating power.
4. Connect the XR-2500A units being used together with two conductor fiber optic cable. Be certain that the "transmit" or "T" connector of one unit is connected to the "receive" or "R" connector of the other unit.
5. The system should now be operational.



---

*Note that the transmitting element in the "-/" single mode version of the XR-2500A uses a solid state Laser Diode located in the optical connector on the unit. This device emits invisible infrared electro-magnetic radiation which, if viewed at close range without a fiber optic cable connected to the optical connector, may be of sufficient intensity to cause instantaneous damage to the retina of the eye. As a result, direct viewing of this radiation should be avoided at all times.*

---

---

---

## Signal and Power Connections

The terminal block connections on the XR-2500A are outlined below and must be compatible with the equipment being used. Be certain to make all connections carefully and check that the correct terminal block positions are being used.

<b>Power Terminal Block</b>	<b>Input</b>
Position 1	14 to 18 VAC 50/60 Hz or +12 to +18 VDC
Position 2	No Connection
Position 3	AC or DC Common

Please note that AC and DC Common are also connected to the enclosure.

Note: It is only necessary to use the +12 to +18 VDC, or the 14 to 18 VAC power input. *Do not use more than one input or damage will occur!*

<b>Signal Terminal Block</b>	<b>Function</b>
Position 1	T-1 (+) Signal to be Transmitted
Position 2	T-1 (-) Signal to be Transmitted
Position 3	T-1 (+) Signal being Received
Position 4	T-1 (-) Signal being Received
Position 5	External Alarm Contacts
Position 6	External Alarm Contacts

---

---

## Operating Pointers

*Input/Output* All input and output signals are transformer coupled and fully *Signals:* compatible with standard T-1 specifications at 1.544 Mbps. The system will only operate within + 10% of this rate.

The T-1 signals accommodated by the transmit section of the XR-2500A are + 3 to + 6 volts. The receive section produces and output level of + 4 volts.

The XR-2500A is designed for standard 1.544 Mbps signals. Other data rates will not operate properly. Signals must not have a bit density of less than 12 % (at least one bit in every 8 must be high). Although this is a normal requirement of standard T1, some non-standard T1 signals may not meet this criteria.

*Indicator LEDs:* The XR-2500A is provided with two signal indicator LEDs to monitor operation. These are labeled “TRANS” or “T” and “REC” or “R”. These indicators turn on whenever the transmitted or received data is present.

*Optical Fiber:* Versions of the XR-2500A are available to drive most multi-mode (MM) and single-mode (SM) optical fibers. The specific models are identified by a suffix at the end of the model numbers as follows:

<b>Fiber Size</b>	<b>Connector</b>	<b>850nm</b>	<b>1300nm</b>
50u, 62.5u MM	ST	-1	-3
50u, 62.5u MM	SMA	-2	-4
8/10u SM	FCPC	-	-7

---

## **Installation of XR-2500A/MCR**

The XR-2500A/MCR is a direct card cage mountable version of the XR-2500A. This unit is designed to plug directly into one position of a Communications Specialties MCR-1000A card cage enclosure. All operating power is provided by the card cage enclosure. The optical and T-1 signal connections are available on connectors mounted on the rear of the plug-in card.

Terminal block positions on the XR-2500A/MCR are the same as for the stand-alone version.

---

---

## INTERFACE TROUBLESHOOTING

The XR-2500A is intended for use with T-1 full duplex equipment. If the system does not operate properly, the following procedure can be used to determine if the XR-2500A is at fault or if the problem lies elsewhere.

### **Transmit Portion**

1. Is operating power connected to the proper terminal block positions?
2. Is a T1 signal present at the input terminals?
3. Is the T1 signal of the correct polarity?
4. Is the T1 input level higher than + 6 volts or lower than + 3 volts?
5. Is the T1 input signal bit density greater than 12 % (1 bit in 8 must be high)?

### **Receive Portion**

1. Is any T1 present at the output terminal block positions?
2. Is the T1 signal polarity connected to the external equipment properly?
3. Is a load impedance of less than 120 ohms present?
4. Is the correct size fiber being used for the particular system?
5. Is the attenuation of the fiber optic cable within the range of the system's loss budget specifications?

If all of the above is correct and the system is still not operating please contact our Customer Service Department.

---

---

## OPERATING CONSIDERATIONS FOR FIBER OPTIC CABLE

The XR-2500A series may be supplied with ST, SMA or FCPC type optical connectors, and will operate with most common fiber optic cables.

Since the system can be provided for operation at a wavelength of 850nm or 1300nm, the fiber optic cable employed should be chosen so that it is optimized for use at the appropriate wavelength.

Due to the small size of the actual optical fiber, correct alignment is imperative, especially with SMA types. When using stepped SMA connectors, be certain that the plastic alignment sleeve is installed at the step on the tip of the connector. The system may not work properly otherwise!

When using any type of fiber optic cable be certain to not cause excessive strains especially at the cable-to-connector junctions. Also, do not subject the cable to sharp bends or pull around sharp corners. Whenever possible, service loops or extra slack should be provided in any installation. While excessive precautions are not necessary, fiber optic cable should be treated with moderate care as it does contain thin, fragile strands of glass.

### Notes Regarding Fiber Optic Cable

Multimode fiber optic cable contains an optical fiber with a light carrying “core” that is only .0025 inches (62.5u) diameter. Single-mode fiber optic cable has an even smaller “core”, only 00032 to .0004 inches (8-10u). This is smaller than a human hair! Any minute particle of dirt or dust can easily block this fiber from accepting or radiating light. *As a result, the key word is cleanliness.* Always use the dust caps provided with all optical connectors whenever they are exposed to air. Also, it is a good idea to gently clean the tip of an optical connector with alcohol whenever dust is suspected.

Mechanical butt splices or optical feedthroughs must be installed properly. Multimode devices will not operate properly with single-mode devices even though they may look the same. Using the wrong device can easily add more attenuation than specified with the result that performance will suffer.

---

---

## OVERALL FIBER SYSTEM CHECKOUT AND TROUBLESHOOTING TECHNIQUES

Occasionally, during the installation of a fiber optic system, difficulties arise that are the result of factors beyond the control of the installer.

It is to simplify the task of the installer that the following general checkout procedure is included.

### A. Check Transmitter or Transmit Section of a Transceiver

1. Is operating power (DC, AC, Voltages) correct?
2. Are the correct pins on the connector or terminal block being used?
3. Is the correct signal level present at transmitter input?
4. Does the transmitting LED glow dimly when a signal is applied? Note that this is only true for an operating wavelength of 850 nm. Units at 1300 nm are totally invisible.\*
5. If the unit is an analog or video transmitter (at 850 nm), is there a continuous dim glow from the transmitting LED? \*
6. Is the optical connector on the transmitting LED clear of any obstruction or minute dirt particles?
7. Does it matter that the power ground and signal ground of many systems are common, matter?
8. Does the fact that the power ground, signal ground, and case are common cause a short circuit anywhere in the system?

\* The above visual check should only be attempted with LEDs.

**NEVER LOOK DIRECTLY AT AN OPERATING  
LASER DIODE, REGARDLESS OF THE  
OPERATING WAVELENGTH**

*US Government regulations require that all equipment using Laser Diodes be clearly identified with appropriate warning labels. Be sure to heed these labels.*

---

---

### *B. Check Optical Connectors*

1. If stepped 906 type SMA optical connectors are being used, are the short plastic alignment sleeves normally supplied with the connectors being used? If they are not present, the system may not work properly!
2. Are the connectors that are being used the correct size for the fiber being used?
3. Are the ends of the connectors free of all dust or dirt? If not, gently clean the tip of the connector with a clean cloth or gauze moistened with alcohol.
4. Is the fiber broken in the connector? A quick inspection with an inexpensive jeweler's loop can determine this.
5. Is the fiber protruding from the tip of the connector? If so, refinishing will be necessary.

### *C. Check Fiber Optic Cable*

1. Is the fiber optic cable pulled too tightly around a sharp corner?
2. Is the correct fiber size being used with the correct transmitter/receiver combination?
3. Does the fiber pass light at all? A small penlight or flashlight can usually be used for this test.
4. Does the fiber have too much attenuation for the system? The attenuation measured on the reel will always be different after the cable is installed.
5. When using very short lengths, less than 10 meters (30 feet), for example, overloading of the receiver may occur. The shorter the length of the fiber, the greater the possibility for this condition. Be sure there is adequate attenuation in any system. If this seems to be the case, or if operation with a meter or so of fiber is required, contact the factory.

---

---

*D. Check Receiver or Receiving Section of a Transceiver*

1. Is the operating power (DC, AC, Voltages) correct?
2. Are the correct pins on the connector or terminal block being used?
3. Is light coming out of the fiber optic cable? This may be difficult to see in many cases, but a dim glow may be present with 850nm light. Other wavelengths, such as 1300 nm, are totally invisible.
4. Is the optical connector on the receiver optical port clear of any obstruction or minute dirt particles?
5. Does it matter the fact that the power ground and signal ground of many systems are common?

---

## **MAINTENANCE**

The Fiberlink XR-2500A has been manufactured using the latest semiconductor devices and techniques that electronic technology has to offer. It has been designed for long, reliable, and trouble free service and is not normally field repairable.

Should difficulty be encountered, Communications Specialties maintains a complete service facility to render accurate, timely and reliable service of all products.

The only maintenance that can be provided by the user is to ascertain that optical connectors are free of dust or dirt that could interfere with light transmission and that electrical connections are secure and accurate.

All other questions or comments should be directed to our Customer Service Department. It should be noted that many “problems” can easily be solved by a simple telephone call.

---

## **WARRANTY**

Communications Specialties warrants that for a period of three years after purchase by the Buyer, all Fiberlink transmission systems will be free from defects in material and workmanship under normal use and service. A Return Material Authorization (RMA) number must be obtained from Communications Specialties before any equipment is returned by the Buyer. All material must be shipped to Communications Specialties at the expense and risk of the Buyer.

Communications Specialties' obligation under this warranty will be limited, at its option, to either the repair or replacement of defective units, including free materials and labor. In no event shall Communications Specialties be responsible for any incidental or consequential damages or loss of profits or goodwill.

Communications Specialties shall not be obligated to replace or repair equipment that has been damaged by fire, war, acts of God, or similar causes, or equipment that has been serviced by unauthorized personnel, altered, improperly installed or abused.

RMA numbers and repairs can be obtained from:

### **WORLDHEADQUARTERS**

**55 Cabot Court**

**Hauppauge, NY 11788 USA**

**TEL: (631) 273-0404 FAX: (631) 273-1638**

**WWW: <http://www.commspecial.com>**

**EMAIL: [info@commspecial.com](mailto:info@commspecial.com)**

### **Communications Specialties Pte Ltd**

**100 Beach Road**

**#22-09 Shaw Tower**

**Singapore 189702**

**TEL: +65 6391 8790 FAX: +65 6396 0138**

**EMAIL: [csiasia@commspecial.com](mailto:csiasia@commspecial.com)**

Please have your serial number available when contacting us.